

## An Autonomous Wireless Modul for Early Warning System of Forest-Fire Based on NTC Sensor

Lazuardi Umar<sup>1</sup>, Erwin<sup>2</sup>

<sup>1,2</sup> Physics Dept, FMIPA University of Riau

Jl. Prof. Dr. Muchtar Lutfi Kampus Bina Widya Pekanbaru 28293

Email: [lazuardi@unri.ac.id](mailto:lazuardi@unri.ac.id)

### Abstract

We have developed a sensor for fire detection in the forest (fire-sensor), which will be applied in rain forest of Sumatra. A prototype of the forest-fire sensor consisted of transmitter and receiver module of STM110 EnOcean Firma of 433MHz ISM Band has been constructed. The fire-sensor module detects the presence of fire in the vicinity using a temperature sensor of the NTC (negative temperature coefficient). The NTC sensor is thermally sensitive resistors (resistance decrease with increasing temperature and made of metal oxides and coated with epoxy or glass with resistance of 470K  $\Omega$ ). The thermistor is mounted on the exterior of the prototype (casing) and its switch-temperature is adjusted between 50°C and 90°C. A rapid rise in the temperature above the setting point indicates the presence of a nearby fire changes the sensor resistance rapidly and therefore, the sensor would send a telegram to the central station (receiver module).

Keywords: forest-fire sensor, transmitter and receiver module, NTC-Sensor, telegram

### 1. INTRODUCTION

One of the main problems in combating wildland fires is monitoring the time history of the fire (Chandler 1983). Understanding the size, location and speed of advance of the fire front is critical to optimal allocation of fire fighting resources and maintaining safety of the fire crew. Investigation of major wildland fire accidents involving loss of life often indicates that the crews became imperiled because of insufficient or untimely information about the location and speed of advance of the fire (Rothermel 1993).

In the dry season fires often occur in the region, especially Sumatra Riau Province where the majority of the land area consists of swamp peat moss. Land peat swamp forests, has economic value to the community in the surrounding forest provides results such as wood, resin, rattan and wood products, and act also as water resources, control floods, store a variety of unique biodiversity and the diversity of functions as the world's carbon absorber. Data and new research shows that 60% of the smoke pollution in Indonesia, including carbon emissions, originating from fires in the peat swamp forest lands that cover only 10-14% of mainland Indonesia. Therefore a system is needed to be able to detect forest fires in the surrounding area so that preventive action can be done immediately.

Much effort has been expended in modeling the movement of fires in wildland settings (Andrews 1986, Finney 1994) but these models are only as good as the detailed weather, terrain and fuel load information. Lacking precise information of the fire site, these complex fire models can predict fire

behavior for short time periods, but then must be 'tuned' with actual data to obtain long-term accuracy. These fire models are similar to modern weather simulations that are similarly adjusted periodically with weather data to provide long-term modeling.

The use of satellites to obtain fire data for model tuning is possible, but there are complications imposed by limited satellite spatial resolution, complicated ground link equipment and short satellite loiter time over the target area. Real time data can be obtained using unmanned or remotely controlled unmanned flying vehicles (UFVs) flying over the fire site. This solution is both complex and difficult to support in the field and would require additional worker training to operate and maintain the UFV. A small number of modul that are located in the forest could provide this data at low cost and with little additional effort in training or support. We present both an advanced and a simple wireless modul concept and show the initial design of a prototype.

Wireless sensor have been widely used from the field of defense and security, survey, health, even in the smart home. In the application in the field survey, a large number of sensors installed in the area to be monitored. Scenarios through detection of forest fire, a fire point detected by one or more sensors, an alarm is generated will be sent to the control center that will collect all the messages so that the alarm that appropriate action can be done. At this paper, an early warning system for fire detection with NTC termistor sensor is presented. The modul observed changes in environmental temperature above a certain temperature threshold and the reported data to a monitoring station for



analysis so that the status of the sensor that can be reported.

In compare to the use of satellites and unmanned aircraft, the modul price is relatively cheap and can report the conditions around the sensor in real time. Because of topographical and geographical of the observed rain forests, the system will allow this data to transmitt using radio signal and the use of solar cells as a source of energy so that the sensor system is a standalone system (autonomous) that does not require maintenance and can work to monitor the fire in the vicinity.

## 2. CONCEPT OF FOREST-FIRE DETECTION

### 2.1. Forest-Fire Scenario

In practice, the sensor modul would be dropped from a spotter plane or placed manually by fire crews over an area where a fire had previously been detected. The mechanical package of the modul can be designed to be canopy penetrating (to descend to the forest floor) or canopy snagging (hangs in the upper branches of the canopy). The devices would periodically report their position and fire status to a central receiver.

After they are deposited in the fire area, modul detector will locate them selves and report their position and fire alarm status. Communication will be provided by a low power radio transceiver which allows modul to-base unit communication. A diagram of the communication links among the various units is shown in Figure 1. Periodically, the modul will report their status to a central control unit. On detection of a fire, the reporting modul will transmit an alarm to the central transceiver. Crews in the area can be alerted either directly from the reporting modul, or through alarm messages that are relayed from the control station. In the future of our research, the control transceiver can have the capability of overlaying geographical information system (GIS) maps with the location and alarm state of the modul, and presenting this data to the incident commander or other personnel at the fire site.

There are many simpler operational modes of the forest-fire modul detector system, one of which is depicted in Figure 1. In this mode, the sensor operate independently of each other, and transmit alarm message consist of ID number of the modul, its position, and the alarm state of the device. This mode of operation is most suitable when a few (~10) moduls are used on geographically small fires.

Several fire sensors may be used in an autonomous modul, such as be smoke detectors (photoelectric or ionization), gas detectors (combustion precursor gases, carbon monoxide, etc.), thermal (temperature), passive microwave or optical radiation detectors. The modul circuit internally measures the strength of signals from the sensors and makes decisions as to the whether or not to issue an alarm. The use of more than one

inexpensive detector can reduce the probability of false alarms greatly while not increasing the cost significantly. In this research, the modul has an internal program that observe and report sensor input periodically and to 'sleep' in the interim to conserve battery energy.

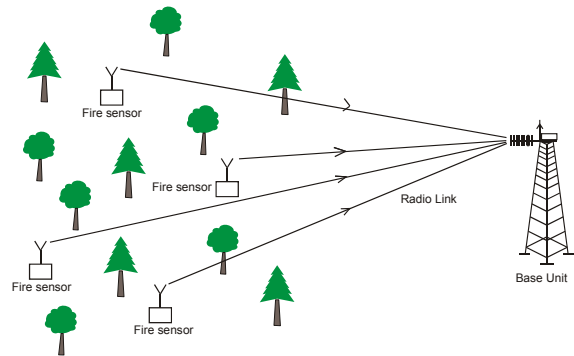

Figure 1. Simple operation of an autonomous forest fire detector for early warning system

### 2.2. NTC Thermistor Sensor

A thermistor is a piece of semiconductor made from metal oxides, pressed into a small bead, disk, wafer, or other shape, sintered at high temperatures, and finally coated with epoxy or glass. The resulting device exhibits an electrical resistance that varies with temperature. There are two types of thermistors – negative temperature coefficient (NTC) thermistors, whose resistance decreases with increasing temperature, and positive temperature coefficient (PTC) thermistors, whose resistance increases with increasing temperature. NTC thermistors are much more commonly used than PTC thermistors, especially for temperature measurement applications [Portland, 2003].

A current flowing through a thermistor may cause sufficient heating to raise the thermistor's temperature above the ambient. As the effects of self-heating are not always negligible (or may even be intended), a distinction has to be made between the characteristics of an electrically loaded thermistor and those of an unloaded thermistor. The properties of an unloaded thermistor are also termed "zero-power characteristics". The dependence of the resistance on temperature can be approximated by the following equation:

$$R = R_0 \cdot \exp\left(\beta \cdot \left(\frac{1}{T} - \frac{1}{T_0}\right)\right) \quad (1)$$

Where  $R_0$  is NTC resistance in  $\Omega$  at rated temperature  $T$  in K,  $T_0$  Temperature in K and  $\beta$  value, material-specific constant of the NTC thermistor. A main advantage of thermistors for

temperature measurement is their extremely high sensitivity. Higher resistance thermistors can exhibit temperature coefficients in comparison to the platinum RTD. The physically small size of the thermistor bead also yields a very fast response to temperature changes.

The resistance-temperature behavior of thermistors is highly dependent upon the manufacturing process. Therefore, thermistor manufacturers have not standardized thermistor curves to the extent that thermocouple or RTD curves have been standardized. Typically, thermistor manufacturers supply the resistance-versus-temperature curves or tables for their particular devices. The thermistor curve, however, can be approximated relatively accurately with the Steinhart-Hart equation:

$$T(K) = \frac{1}{a_0 + a_1 \ln(R_T) + a_2 [\ln(R_T)]^3} \quad (2)$$

Where T(°K) is the temperature in degrees Kelvin, equal to T(°C) + 273.15, and  $R_T$  is the resistance of the thermistor. The coefficients  $a_0$ ,  $a_1$ , and  $a_2$  can be provided by the thermistor manufacturer, or calculated from the resistance-versus-temperature curve.

### 2.3. Wireless Data Transmission

The sensor modul will be installed mainly in endemic areas of the regional fire monitoring. In order to supply energy during operation, the module has been equipped with mini solar cell that can supply the energy needs for the operation of the sensor. Due to distance between measurement and display, the system use an installation that allows to transmit data measurements. This situation is achievable if the forest fire monitoring station located at the spot in the fores [Jones et al, 1973]. In this research, we have used a wireless modul work at the frequency of radio waves in the ISM 315-916MHz.

## 3. PROTOTYPE DESIGN

### 3.1. Transmitter-Receiver Modul

In this research, we have constructed a prototype an autonomous forest-fire sensor consist of transmitter and receiver station, were obtained from the EnOcean Firma. Any design must be sensitive to the multiple design constraints of low cost, ruggedness, low power consumption and transmitting range. The prototype is a transmit-only device and uses a simple messaging system to report the unit ID number and alarm. The units use ISM Band 868.3 MHz with 10 mW transmission power to transmit digital information at 9600 bits per second. The entire transmission lasts under a second, conserving battery power. A radio receiver-

demodulator attached via a serial link to a laptop computer receives the data stream and displays the messages. A photograph of the circuit boards of transmitter EnOcean STM110 and receiver RCM120 are shown in Figure 2.

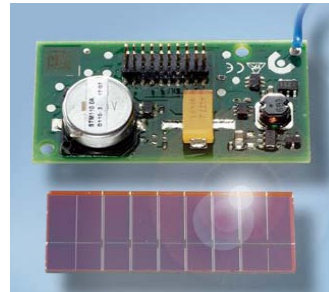

Figure 2a Modul of EnOcean Fa with mini solar cell



Figure 2b. Receiver modul of EnOcean

The transmitter modul consist of three 8-bit A/D converter inputs and 4 digital inputs facilitate multifunctional detector systems, based on passive sensing components. This allows easy and convenient monitoring of temperature, illumination, or controlling window and door states – or supervising input voltages or input currents respectively. The STM 110 module serves the 868 MHz air interface protocol of EnOcean.

### 3.2. Sensor Circuit

In this section, NTC temperature sensor is positioned in a negative feedback of IC1 so that changes due to increasing of NTC temperature will affect the feedback IC1 and amplication factors. The input difference is determined through voltage divider R1 and R2 and R3 provided by the reference voltage obtained from the transmitter module. While energy for operation of the module is limited, the using signal processing components special types of SMD which requires 1-10mA current to the series of transmission is a critical factor for the circuit.

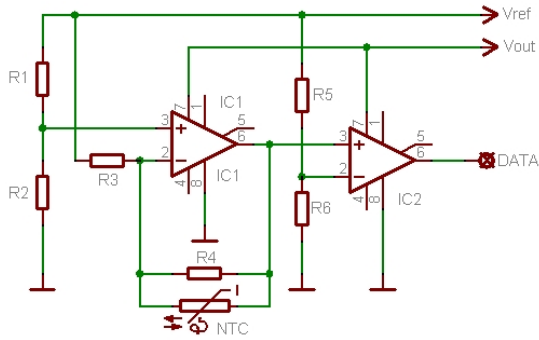

Figure 3. Circuit for forest fire detection

On this module, there was a NTC sensor placed outside. The Sensor will be active on the threshold temperature. It was set at a temperature of approximately 95°C, see Figure 4. A rapid temperature change above the setting temperature indicates a fire in the vicinity and it will promptly change the sensor resistivity so that the sensor module will send a telegram to the main station.

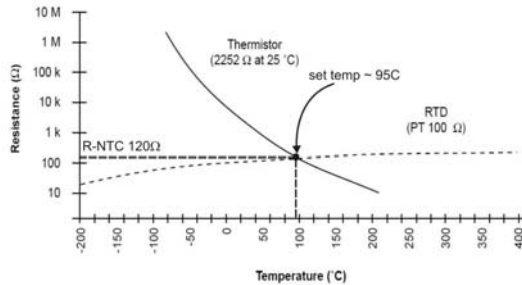

Figure 4. Setting temperature of NTC sensor

#### 4. RESULTS AND DISCUSSION

After detector circuit was fabricated using NTC thermistor sensor, and transmitter circuit using EnOcean STM module 110xx module and receiver RCM110 module, the system were tested using artificial fire. Both modules are shown in the Figure 5 below. The results from this experiment are expected to be the information obtained from a series of recipient and displayed on the screen in the condition on fire or not.

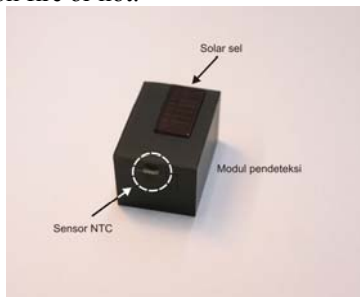

Figure 5a. Autonomous sensor module packed in fire-resistant plastic box transmitter

Figure 5a show autonomous sensor module packed in fire-resistant plastic box (a) transmitter and (b) receiver equipped with serial data to PC.

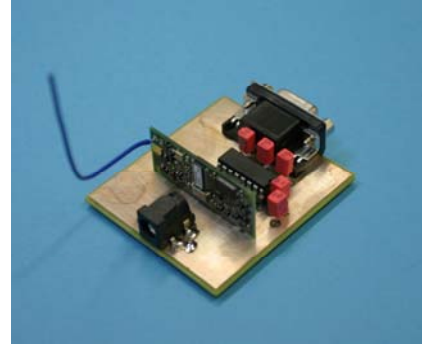

Figure 5b. Receiver sensor module equipped with serial data to computer.

Due to the rapid change in temperature around the module because of fire, module transmitter sent the data to the receiver and data was then processed to display. On this research, a Delphi based software has been developed to demonstrate ("fire") or ("no fire") sign as shown in the Figure 6, below.



Figure 6. Simple display show the sensor status in operationi

After the experiment, it is found that the threshold temperature sensor was relatively high so that it took a long time until the fire detected. Overall, the sensor worked properly. Therefore, for the next research, the temperature threshold has to be lower than 90° C. However, the detector system that has been developed still has limited power. It is scattered in the 300m free space, so that there is still a challenge for further development the sensor using network system to overcome the signal coverage limitations and any difficulties due to the forest topography being monitored.

On the realization, the transmitter module will be placed in the endemic fire areas. It is probably burnt out by fire itself. In this research, the transmitter module was placed in a particular hard plastic waterproof by considering the humidity factor of tropical forest that may disrupt the system of electronic transmitter. For transmitter module can still send out the telegram signal before burnt out, the series of the electronic transmitter was coated with epoxy glue and the overall coated with fire-resistant gypsum. Therefore, modules and receiver series were expected to be as small as possible, so that the cost of the fire monitoring can be minimized. Level of installation is needed to be

considered in fire endemic area. Figure 7 shows module installation at a tree limb.

In this research, module was attached by using special glue, by considering the suitable location of NTC to be placed to detect temperature changes. NTC sensors were remaining below, while the solar cells as energy support system facing outward to absorb energy.

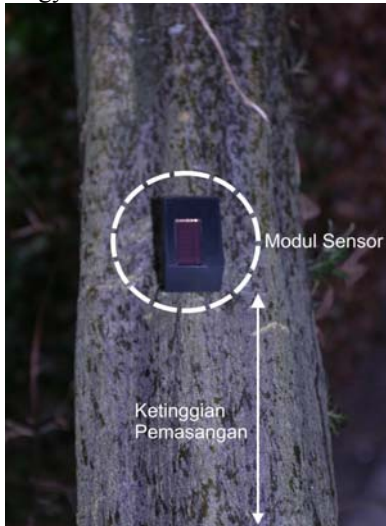

Figure 7. Sensor mounting above the trees

However, wild animals and humans need to be considered for the security reason. This kind of interference would be critical to avoid any disturbance if a fire occurs in the base of forest. From the whole experiment, the system was working well but still need to consider the limited distance dispersed from the module to module. It can be solved using networking system. These sensors are placed in a matrix and each sensor will communicate each other to report the position of fire. It was already found out that the trigger temperature of 95 °C were too high. The sensor has been damaged before the data sent. So, it is need to study the appropriate temperature threshold to send data fire.

#### 4. SUMMARY

From this preliminary research, a series of simple prototype has successfully developed to detect forest fire. Thermistor NTC has been used as temperature sensor to detect temperature changes in the surrounding air. There are several things need to be considered for the development of future research. First, it is related to the capability of transmission modules in the sense of coverage. It can be solved by using networking system where the sensor is arranged in the form of a matrix. It can also communicate each other to report the fire position (which sensor is active). Second, it is related to harmful things happen due to natural condition, such as as rainfall, humidity and the security of wild animals or humans. It can be solved by utilizing high resistant apparatus to such natural condition. Simple

system as a whole has been able to detect a fire and is expected to be developed further.

#### REFERENCES

1. Andrews PL (1986) BEHAVE: fire behavior prediction and fuel modeling system - BURN, subsystem, Part I. United States Department of Agriculture, Forest Service, Intermountain Research Station General Technical Report, INT-194, Ogden, Utah. 130 pages.
2. Andrews PL, Bevins CD (1998) Update and expansion of the BEHAVE fire behavior prediction system. 3rd International Conference on Forest Fire Research; 14th Conference on Fire and Forest Meteorology, 21 - 22 November 1998, Luco-Coimbra, Portugal, Vol. I, pp. 733-740.
3. Chandler C, Cheney P, Thomas P, Traubaud L, Williams D (1983) Fire in forestry, Vol. II, (John Wiley and Sons: New York, USA)
4. Finney MA (1994) FARSITE: a fire area simulator for fire managers. The Biswell Symposium, February 15-17, 1994. Walnut Creek, California.
5. Portland State Aerospace, Negative Temperature Coefficient for Temperature Measurement, Internal Report, 2003
6. Rothermel RC (1993) Mann gulch fire: a race that couldn't be won. United States Department of Agriculture, Forest Service, Intermountain Research Station General Technical Report, INT-299, 346, Ogden, Utah
7. R.V. Jones and J.C.S. Richards. 1973. The design and some applications of sensitive capacitance micrometers. J. Phys. E: Sci. Instrument 6, 589-600